

# **Kawasaki**

— ENGINES —

---

## PARTS CATALOG

### 4-STROKE AIR-COOLED GASOLINE ENGINE

<b>PRODUCT CODE</b>
<b>FS691V-AG80</b>
<b>FS691V-BG80</b>

# PARTS CATALOG INTRODUCTION

This parts catalog lists parts and sub-assemblies provided as service parts. When it becomes necessary to replace parts, always use KAWASAKI GENUINE PARTS which have passed strict inspection which guarantees quality and performance.

## 1. HOW TO ORDER PARTS

- 1) When ordering the parts, be sure to use the parts catalog corresponding to the product code. Check the product revision codes on the product and the catalog.

Product Code (example) : FA130D-AA00  
 Product Revision Code

- 2) Specify the part code (all digits) exactly as listed in this catalog on your parts order.
- 3) The parts not shown in the illustrations of this catalog are not sold separately; only the complete units or next higher assemblies illustrated are supplied as the service parts.

## 2. EXPLANATION OF PARTS CATALOG FORMAT

**1** FJ180V- M24

**2** B-08. ELECTRIC-EQUIPMENT

**5** E0160-B181B

**7** ⑥

Ref. No.	Part No.	Description	Quantity
14091	14091-2141	COVER	1
19073	19073-2241	INSULATOR	1
21169	21169-2077	TERMINAL	1
21171	21171-2267	COIL-ASSY-IGNITION	1
21194	21194-2355	FLYWHEEL-COMP	1
29011	29011-2390	WIRE-LEAD	1
92038	92038-2107	KEY	1
92070	92070-2119	PLUG-SPARK(BPRSES(NGK)	1
92154	92154-2014	BOLT,4X18	1
92154A	92154-2018	BOLT,6X20	2
92154B	92154-2017	BOLT,12X30	1
92200	92200-2183	WASHER,4.5X8X0.5	1
92210	92210-2126	NUT,M4	1

### 1) Product Code

This code describes the product code covered by this catalog. The product revision code, which is a part of the product code, is omitted.

### 2) Part Group Title

This title is the representative name for the group of parts illustrated on the page.

### 3) Reference Number

The reference numbers are shown on the illustration and the list as the link between them.

## 4) Part Number

This is the key of your parts ordering. Three kinds of part number are used in this catalog.

### a. Structure 1

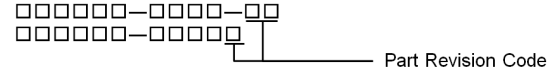

### b. Structure 2

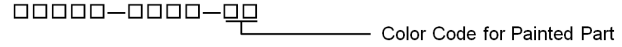

### c. Standard Hardware Number

(for bolts, nuts, washer, or the like)



## 5) Description and Additional Information

The part name, the location, the size, and the serial number as additional information, etc. are described here. Use them to find out and check the part required.

When a part number is changed without change of the product revision code and the changed parts are not interchangeable, the serial number of the product is noted as follows;

- ( - FA130 - 100001) Affected units are from beginning of the product of the product code up to and including this serial number.
- (FA130 - 100002 - ) Affected units are from this serial number and above.
- (FA130 - 100002 - FA130 - 110001) Affected units are in this serial number range.

## 6) Quantity

The figure shows quantity of the part required at the indicated position on the illustration and for the specified product revision code.

The asterisk (\*) on this column means the part can be used as the substitute on the product and is supplied until the stock is exhausted.

Note: Some small parts will be supplied by units.

Example: If six (6) bolts are ordered and the minimum quantity per unit is five (5), two (2), units of the bolt will be delivered.

## 7) Product Revision Code

This Code indicates an important change which affects the service parts interchangeability.

## 3. ABBREVIATIONS

#	Number	FR	Front	RH	Right Hand
&	And	G	Gram	RPM	Revolutions Per Minute
(+)	Plus	HEX	Hexagonal	RR	Rear
(-)	Minus	ID =	Inside Diameter	STD	Standard
2ND	Second	IN	Inch	T	Teeth
3RD	Third	L =	Length	T =	Thickness
4TH	Fourth	LH	Left Hand	U/S	Under Size
A	Ampere	LWR	Lower	UPP	Upper
AR	As Required	MM	Millimeter	V	Volt
ASSY	Assembly	O/S	Over Size	W	Watt
CNT	Center	OD =	Outside Diameter		
COMP	Complete	REF	Reference		

E0110-A974B

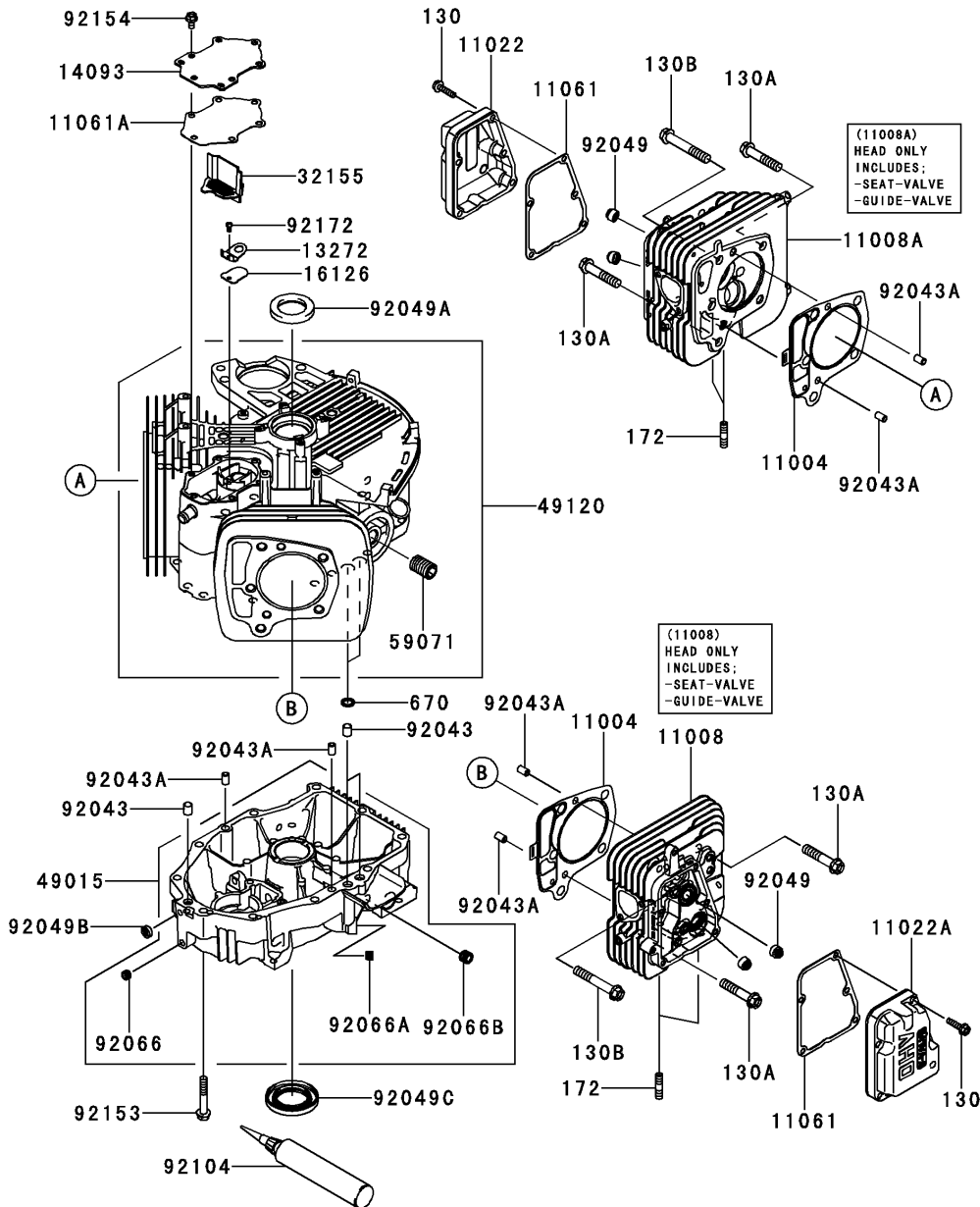

01. CYLINDER/CRANKCASE

Ref. No.	Part No.	Description	Quantity	
			AG80	BG80
11004	11004-7026	GASKET-HEAD	2	2
11008	11008-0845	HEAD-COMP-CYLINDER,#2	1	1
11008A	11008-0861	HEAD-COMP-CYLINDER,#1	1	1
11022	11022-0046	CASE-ROCKER,#1CYL	1	1
11022A	11022-0047	CASE-ROCKER,#2CYL	1	1
11061	11061-1285	GASKET,CASE-ROCKER	2	2
11061A	11061-7094	GASKET,BREATHER	1	1
13272	13272-1374	PLATE	1	1
14093	14093-0455	COVER,BREATHER	1	1
16126	16126-7020	VALVE,BREATHER	1	1
32155	32155-2214	PIPE,BREATHER	1	1
49015	49015-0023	COVER-CRANKCASE	1	1
49120	49120-0858	CRANKCASE-COMP	1	1
59071	59071-0733	JOINT	1	1
92043	92043-0858	PIN	3	3
92043A	92043-1263	PIN,6.2X8X14	6	6
92049	92049-7001	SEAL-OIL,RVC2 6X11X10.2	4	4
92049A	92049-7010	SEAL-OIL,SD 35X48X8 R HS	1	1
92049B	92049-7019	SEAL-OIL,SO 8X14X5 HS	1	1
92049C	92049-7028	SEAL-OIL,38X62X8MTCLV	1	1
92066	92066-0880	PLUG,OIL	1	1
92066A	92066-0881	PLUG	1	1
92066B	92066-2223	PLUG	1	1
92104	92104-0007	GASKET-LIQUID,TB1217H	AR	AR
92153	92153-7054	BOLT,8X50	10	10
92154	92154-2938	BOLT,6X12	6	6
92172	92172-0870	SCREW,4X8	1	1
130	130BA0625	BOLT-FLANGED,6X25	10	10
130A	130CA1050	BOLT-FLANGED,10X50	4	4
130B	130CA1065	BOLT-FLANGED,10X65	6	6
172	172BA0822	BOLT-STUD,8X22	4	4
670	670B2011	O RING,11MM	2	2

E0120-A557B

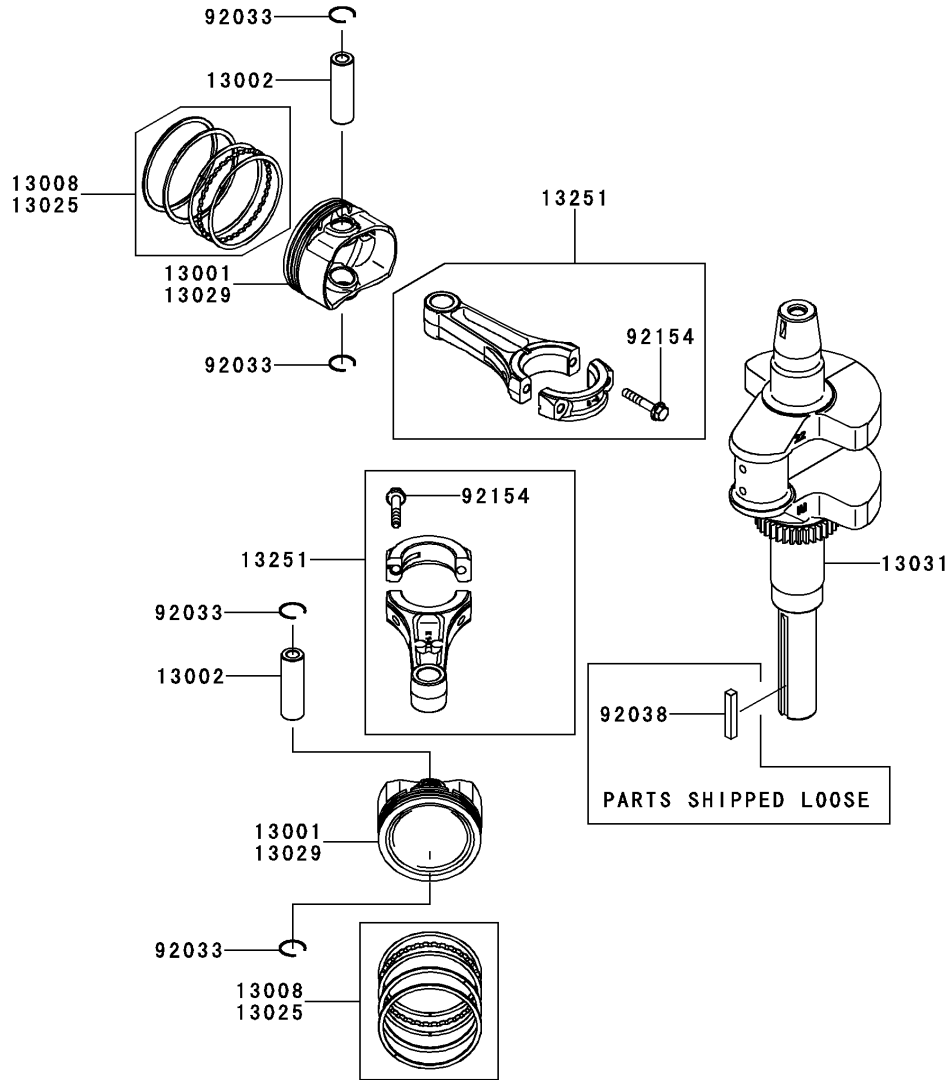

02. PISTON/CRANKSHAFT

Ref. No.	Part No.	Description	Quantity	
			AG80	BG80
13001	13001-7027	PISTON-ENGINE	2	2
13002	13002-0704	PIN-PISTON	2	2
13008	13008-0569	RING-SET-PISTON	2	2
13025	13025-7009	RING-SET-PISTON L,0.5	AR	AR
13029	13029-7010	PISTON-ENGINE L,0.5	AR	AR
13031	13031-0824	CRANKSHAFT-COMP	1	1
13251	13251-0719	ROD-ASSY-CONNECTING	2	2
92033	92033-0790	RING-SNAP	4	4
92038	92038-2101	KEY	1	1
92154	92154-2842	BOLT,6X35	4	4



E0140-A506R

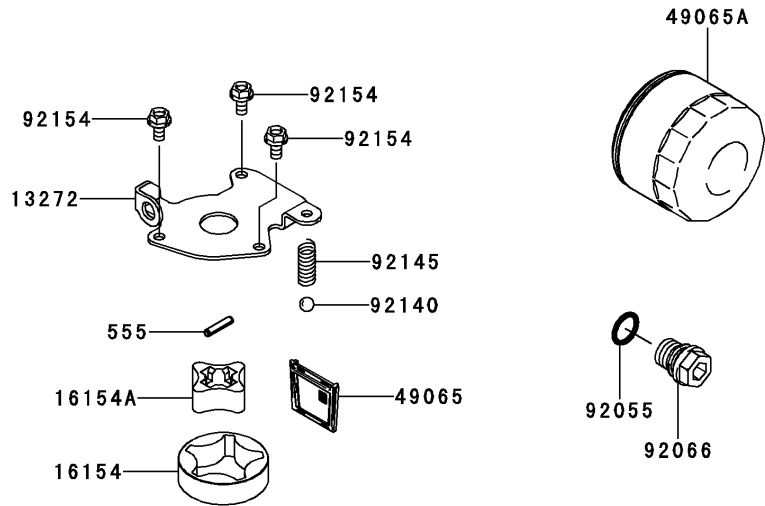
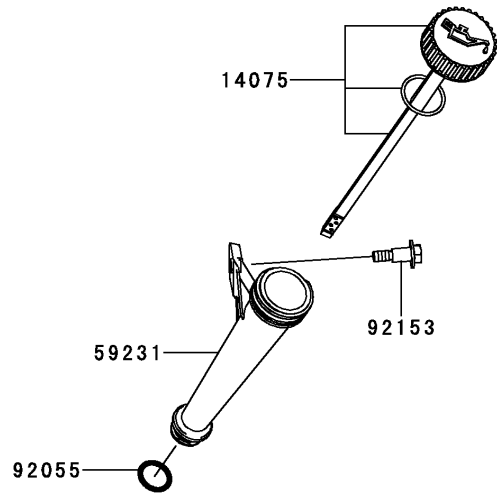

04. LUBRICATION-EQUIPMENT

Ref. No.	Part No.	Description	Quantity	
			AG80	BG80
13272	13272-7011	PLATE,ROTOR	1	1
14075	14075-0707	CAP-ASSY	1	1
16154	16154-7010	ROTOR-PUMP,OUTER	1	1
16154A	16154-7011	ROTOR-PUMP,INNER	1	1
49065	49065-7006	FILTER-OIL	1	1
49065A	49065-7007	FILTER-OIL	1	1
59231	59231-0746	FILLER	1	1
92055	92055-0892	RING-O,15.8X2.4	2	2
92066	92066-0774	PLUG	1	1
92140	92140-7003	BALL,STEEL,13/32	1	1
92145	92145-1809	SPRING,OIL RELIEF	1	1
92153	92153-7008	BOLT	1	1
92154	92154-2938	BOLT,6X12	3	3
555	555A0420	PIN-SPRING,4X20	1	1

E0150-B383A

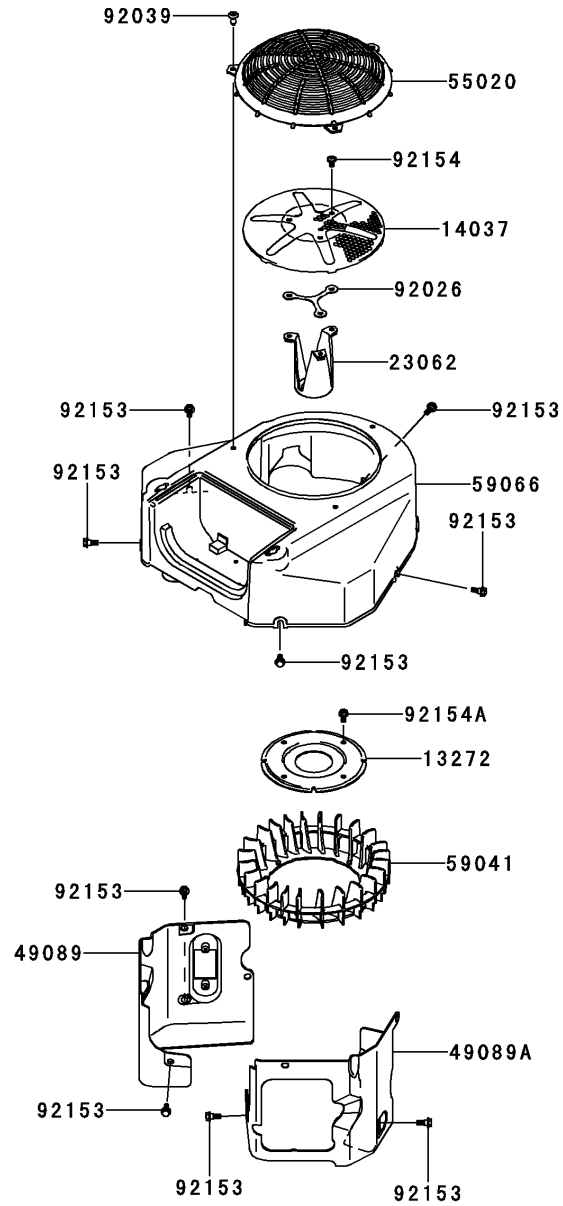

05. COOLING-EQUIPMENT

Ref. No.	Part No.	Description	Quantity	
			AG80	BG80
13272	13272-1487	PLATE,FAN	1	1
14037	14037-7008-9H	SCREEN	1	1
23062	23062-7024	BRACKET-COMP	1	1
49089	49089-0991	SHROUD-ENGINE	1	1
49089A	49089-0992	SHROUD-ENGINE	1	1
55020	55020-0900	GUARD	1	1
59041	59041-7014	FAN	1	1
59066	59066-0043	HOUSING-FAN	1	1
92026	92026-7007	SPACER	1	1
92039	92039-0751	RIVET, GUARD	3	3
92153	92153-7007	BOLT, FLANGED, 6X16	9	9
92154	92154-2687	BOLT, 6X12	3	3
92154A	92154-2938	BOLT, 6X12	4	4

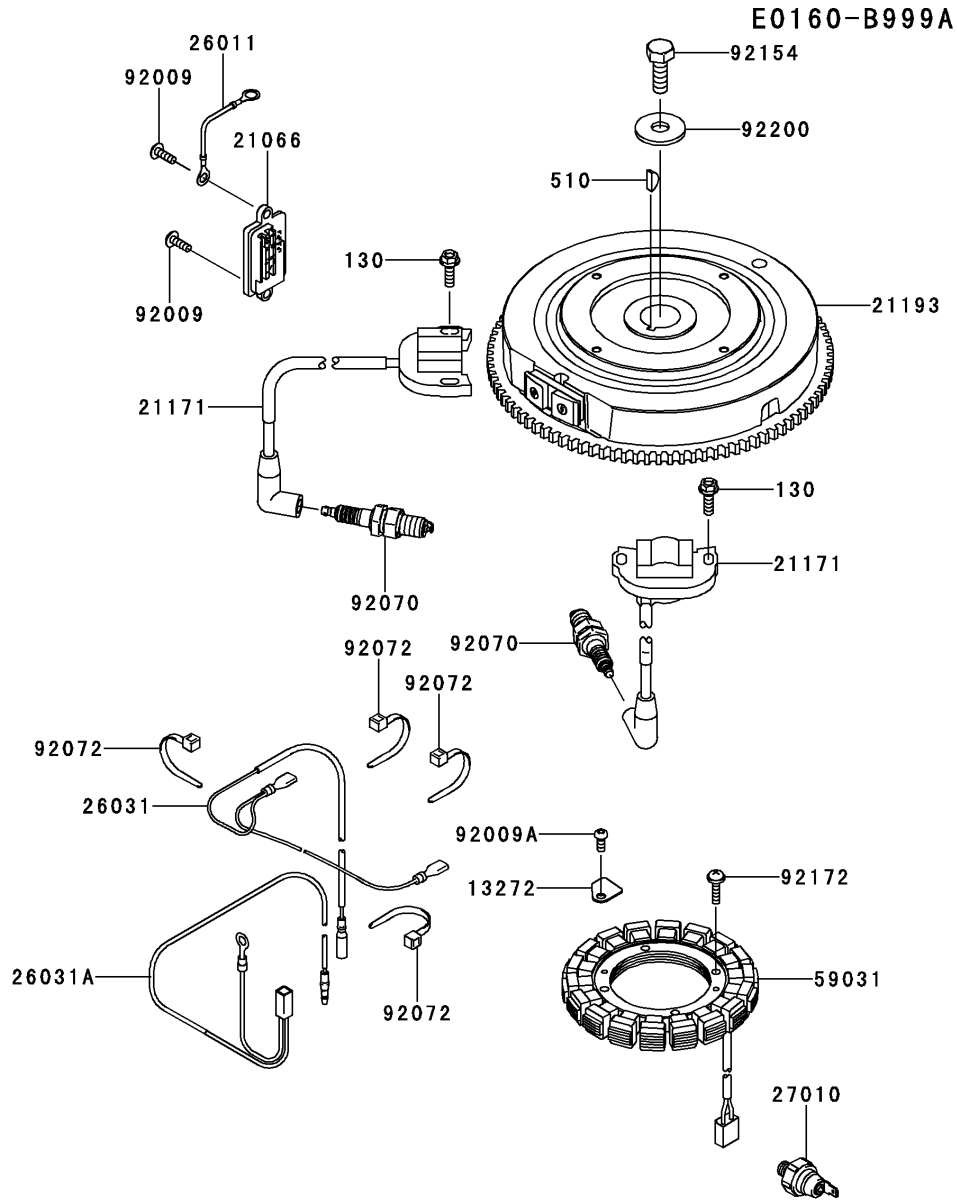

Ref. No.	Part No.	Description	Quantity	
			AG80	BG80
13272	13272-7012	PLATE	1	1
21066	21066-7017	REGULATOR-VOLTAGE	1	1
21171	21171-0758	COIL-ASSY-IGNITION	2	2
21193	21193-0036	FLYWHEEL-ASSY	1	1
26011	26011-2234	WIRE-LEAD	1	1
26031	26031-7040	HARNESS	1	1
26031A	26031-7041	HARNESS	1	1
27010	27010-0818	SWITCH	1	1
59031	59031-7017	COIL-CHARGING	1	1
92009	92009-2303	SCREW	2	2
92009A	92009-2308	SCREW	1	1
92070	92070-7004	PLUG-SPARK,BPR4ES(NGK),SOLID	2	2
92072	92072-7003	BAND	4	4
92154	92154-7003	BOLT,12X30	1	1
92172	92172-7018	SCREW,5X20	4	4
92200	92200-7002	WASHER	1	1
130	130BA0620	BOLT-FLANGED,6X20	4	4
510	510A5100	KEY-WOODRUFF	1	1



E0170-A753J

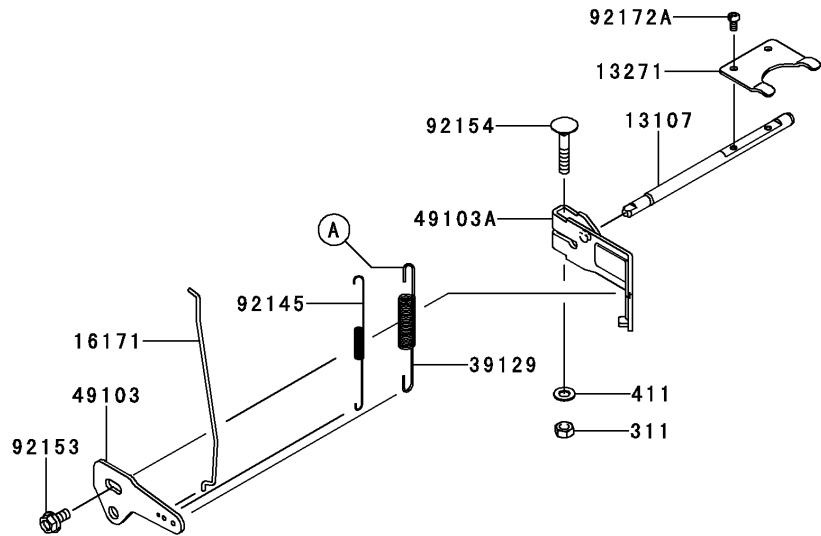
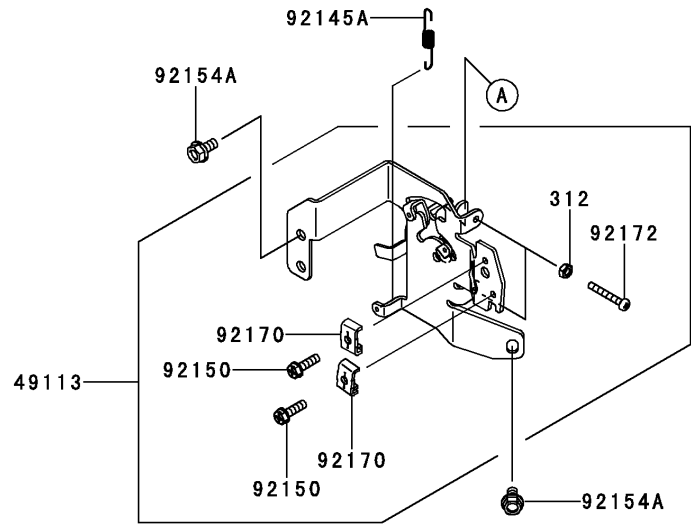

07. CONTROL-EQUIPMENT

Ref. No.	Part No.	Description	Quantity	
			AG80	BG80
13107	13107-7047	SHAFT,GOVERNOR	1	1
13271	13271-7038	PLATE	1	1
16171	16171-0042	LINK	1	1
39129	39129-7035	SPRING-GOVERNOR	1	1
49103	49103-0010	ARM-GOVERNOR	1	1
49103A	49103-7014	ARM-GOVERNOR	1	1
49113	49113-0727	PANEL-COMP-CONTROL	1	1
92145	92145-1811	SPRING,LINK	1	1
92145A	92145-1812	SPRING	1	1
92150	92150-2182	BOLT,5X18	2	2
92153	92153-0009	BOLT,6X12	1	1
92154	92154-2697	BOLT,6X35	1	1
92154A	92154-2938	BOLT,6X12	2	2
92170	92170-7001	CLAMP	2	2
92172	92172-0792	SCREW,5X35	2	2
92172A	92172-0870	SCREW,4X8	2	2
311	311BA0600	NUT-HEX,6MM	1	1
312	312AA0500	NUT-HEX,5MM	2	2
411	411AA0600	WASHER-PLAIN,6MM	1	1

E0180-B143A

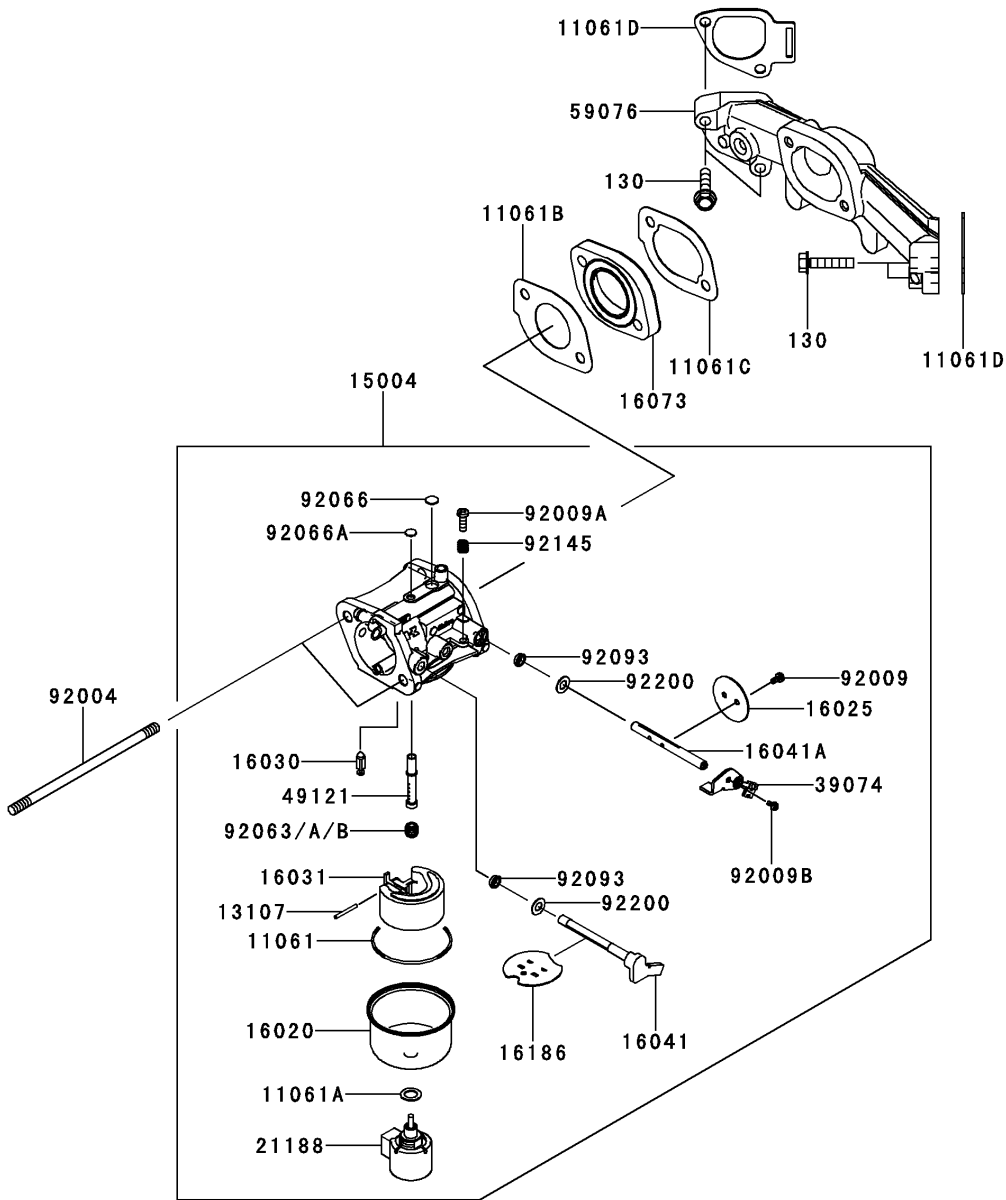

08. CARBURETOR

Ref. No.	Part No.	Description	Quantity	
			AG80	BG80
11061	11061-7009	GASKET,CHAMBER	1	1
11061A	11061-7010	GASKET,SCREW	1	1
11061B	11061-7087	GASKET,INSULATOR	1	1
11061C	11061-7088	GASKET,INSULATOR/MANIFOLD	1	1
11061D	11061-7093	GASKET,MANIFOLD	2	2
13107	13107-7018	SHAFT	1	1
15004	15004-0985	CARBURETOR-ASSY	1	1
16020	16020-7003	CHAMBER-FLOAT	1	1
16025	16025-7017	VALVE-THROTTLE	1	1
16030	16030-7003	VALVE-FLOAT	1	1
16031	16031-7002	FLOAT	1	1
16041	16041-0007	SHAFT-CARBURETOR,CHOKE	1	1
16041A	16041-7051	SHAFT-CARBURETOR,THROTTLE	1	1
16073	16073-7013	INSULATOR	1	1
16186	16186-7006	VALVE-ASSY-CHOKE	1	1
21188	21188-7002	SOLENOID	1	1
39074	39074-7001	LEVER-ASSY-THROTTLE	1	1
49121	49121-7018	NOZZLE-MAIN	1	1
59076	59076-0009	MANIFOLD-INTAKE	1	1
92004	92004-0723	BOLT-STUD,6X115	2	2
92009	92009-2083	SCREW	2	2
92009A	92009-2349	SCREW	1	1
92009B	92009-2402	SCREW	1	1
92063	92063-7141	JET-MAIN,#122,3280FT (OPTION)	1	1
92063A	92063-7142	JET-MAIN,#124	1	1
92063B	92063-7149	JET-MAIN,#120,6560FT (OPTION)	1	1
92066	92066-2204	PLUG	1	1
92066A	92066-2244	PLUG	1	1
92093	92093-0593	SEAL	2	2
92145	92145-1579	SPRING	1	1
92200	92200-0848	WASHER	2	2
130	130BA0630	BOLT-FLANGED,6X30	4	4

E0190-B688A

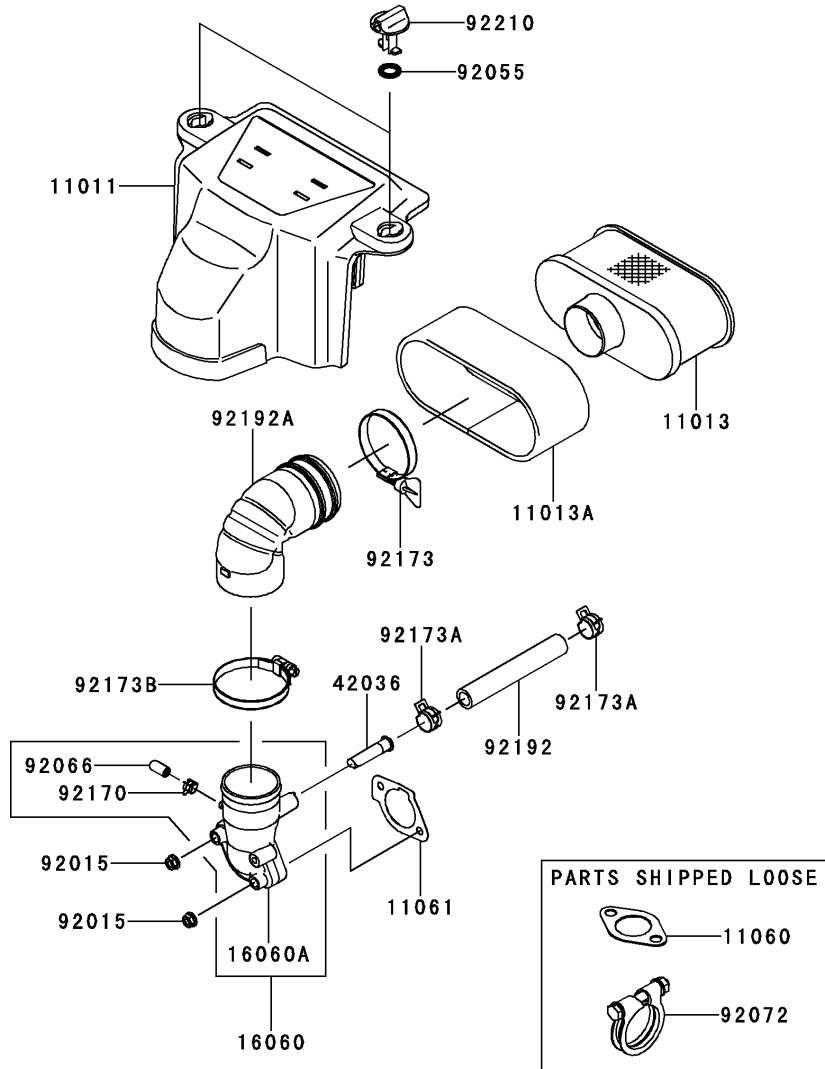

09. AIR-FILTER/MUFFLER

Ref. No.	Part No.	Description	Quantity	
			AG80	BG80
11011	11011-0786	CASE-AIR FILTER	1	1
11013	11013-0752	ELEMENT-AIR FILTER	1	1
11013A	11013-7046	ELEMENT-AIR FILTER	1	1
11060	11060-7016	GASKET,MUFFLER	2	2
11061	11061-7086	GASKET,CARBURETOR/PIPE-INTAKE	1	1
16060	16060-0048	PIPE-INTAKE	1	1
16060A	16060-7038	PIPE-INTAKE	1	1
42036	42036-7022	SLEEVE,BREATHER	1	1
92015	92015-1367	NUT,FLANGED,6MM	2	2
92055	92055-7025	RING-O	2	2
92066	92066-0095	PLUG	1	1
92072	92072-7013	BAND	1	1
92170	92170-2042	CLAMP	1	1
92173	92173-1001	CLAMP	1	1
92173A	92173-7003	CLAMP	2	2
92173B	92173-7010	CLAMP	1	1
92192	92192-7146	TUBE,12.6X18.6X118	1	1
92192A	92192-7165	TUBE	1	1
92210	92210-1730	NUT	2	2

E0200-B028A

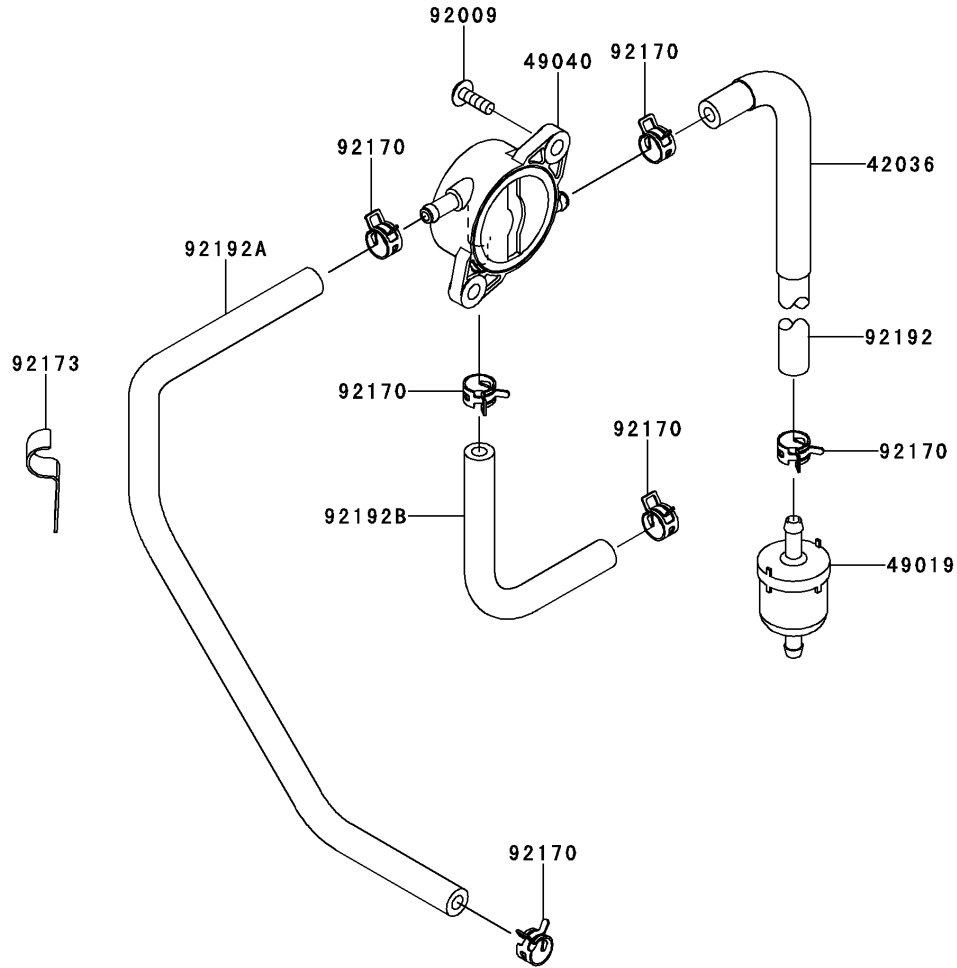

## 10. FUEL-TANK/FUEL-VALVE

Ref. No.	Part No.	Description	Quantity	
			AG80	BG80
42036	42036-7015	SLEEVE	1	1
49019	49019-0027	FILTER-FUEL	1	1
49040	49040-0770	PUMP-FUEL	1	1
92009	92009-2303	SCREW	2	2
92170	92170-2009	CLAMP	6	6
92173	92173-1000	CLAMP	1	1
92192	92192-1551	TUBE,6.35X12.7X185	1	1
92192A	92192-1555	TUBE,6.35X12.7X390	1	1
92192B	92192-7148	TUBE,6.4X12.7X150	1	1

E0210-A726A

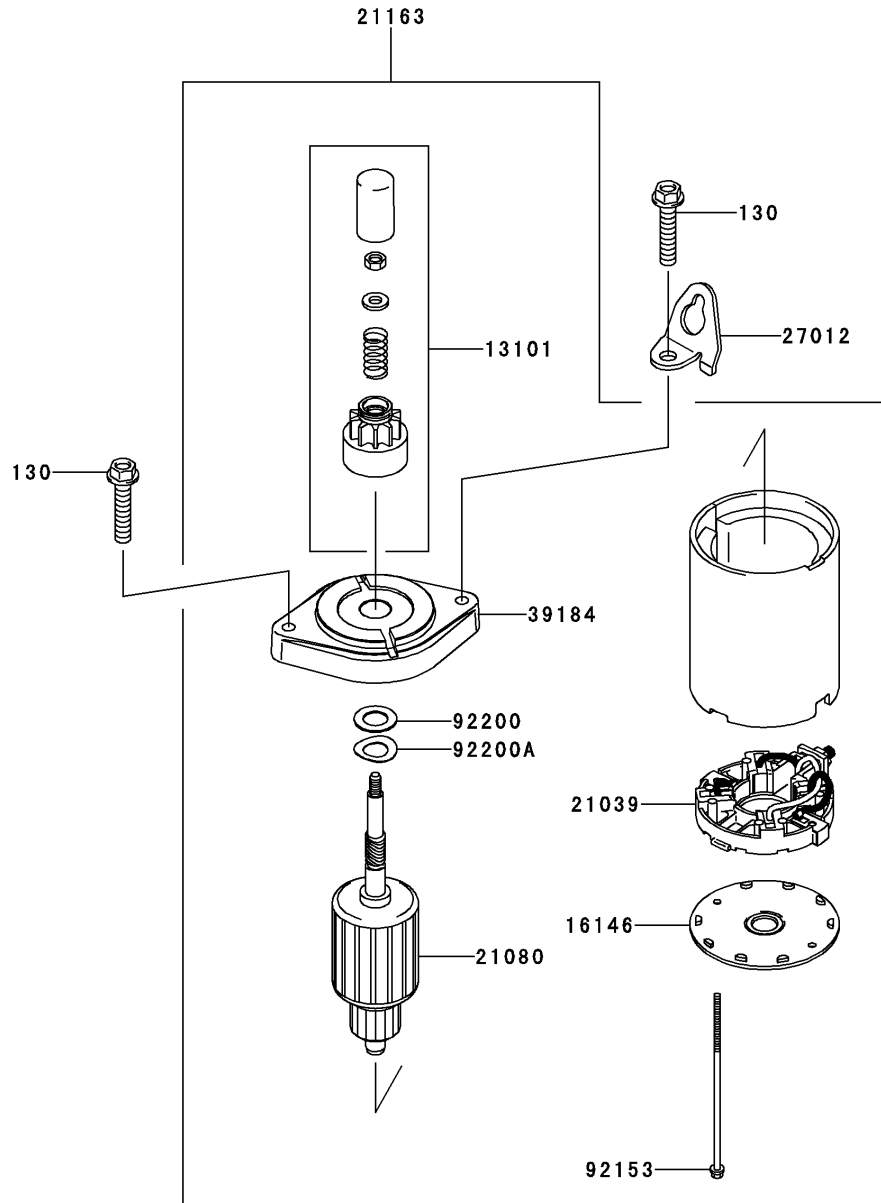

## 11. STARTER

Ref. No.	Part No.	Description	Quantity	
			AG80	BG80
13101	13101-0650	GEAR-ASSY	1	1
16146	16146-7013	COVER-ASSY	1	1
21039	21039-7002	BRUSH	1	1
21080	21080-0009	ARMATURE	1	1
21163	21163-0749	STARTER-ELECTRIC	1	1
27012	27012-7008	HOOK	1	1
39184	39184-0019	BRACKET-ASSY	1	1
92153	92153-7034	BOLT	2	2
92200	92200-7023	WASHER	1	1
92200A	92200-7024	WASHER	1	1
130	130BA0840	BOLT-FLANGED,8X40	2	2

F0290-B859A

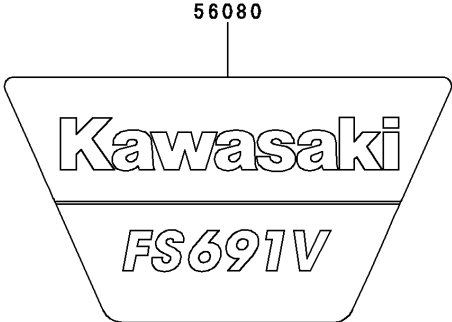
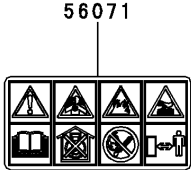
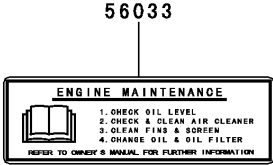

12. LABEL

Ref. No.	Part No.	Description	Quantity	
			AG80	BG80
56033	56033-7001	LABEL-MANUAL	1	1
56071	56071-0366	LABEL-WARNING	1	1
56080	56080-0746	LABEL-BRAND	1	1

F0300-A001A

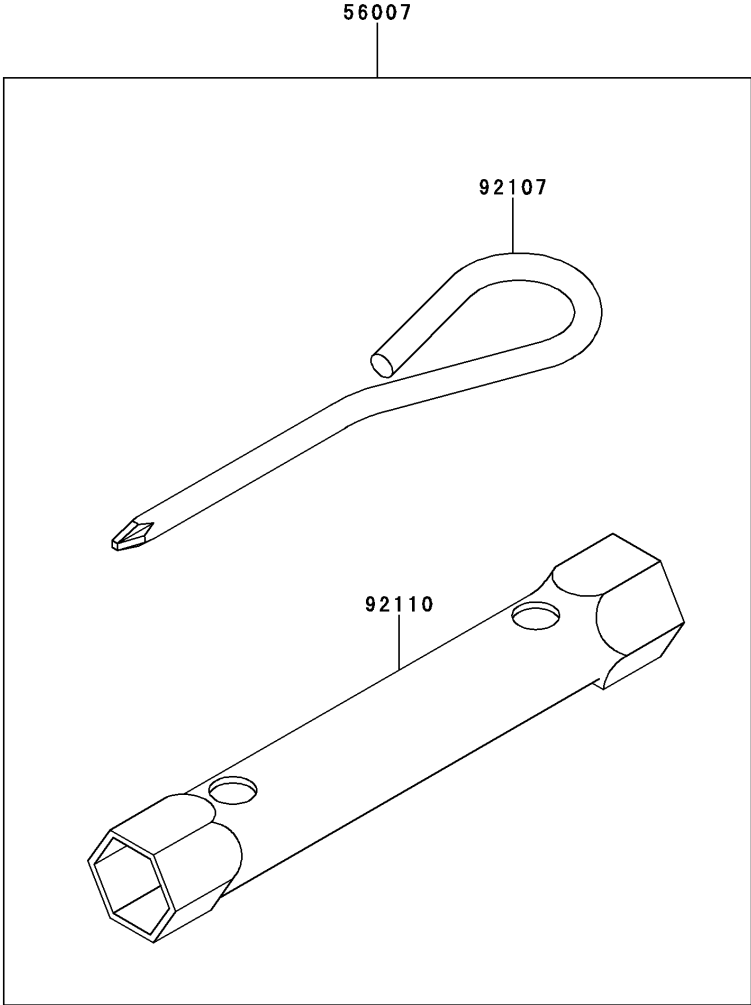

13. TOOL

Ref. No.	Part No.	Description	Quantity	
			AG80	BG80
56007	56007-2051	TOOLKIT	1	1
92107	92107-2057	TOOL-DRIVER	1	1
92110	92110-2051	TOOL-WRENCH,19X21	1	1

**FS691V- AG80/BG80**

**NUMERICAL PARTS INDEX**

Part No.	Fig No.	Part No.	Fig No.	Part No.	Fig No.	Part No.	Fig No.	Part No.	Fig No.	Part No.	Fig No.
11004-7026	01	14075-0707	04	49089-0992	05	92066-2223	01	92200-0945	03		
11008-0845	01	14093-0455	01	49103-0010	07	92066-2244	08	92200-2151	03		
11008-0861	01	15004-0985	08	49103-7014	07	92070-7004	06	92200-7002	06		
11011-0786	09	16020-7003	08	49113-0727	07	92072-7003	06	92200-7023	11		
11013-0752	09	16025-7017	08	49118-7022	03	92072-7013	09	92200-7024	11		
11013-7046	09	16030-7003	08	49120-0858	01	92093-0593	08	92200-7048	03		
11022-0046	01	16031-7002	08	49121-7018	08	92104-0007	01	92210-1730	09		
11022-0047	01	16041-0007	08	510A5100	06	92107-2057	13				
11055-7009	03	16041-7051	08	55020-0900	05	92110-2051	13				
11060-7016	09	16060-0048	09	555A0420	04	92140-7003	04				
11061-1285	01	16060-7038	09	56007-2051	13	92140-7005	03				
11061-7009	08	16073-7013	08	56033-7001	12	92145-1579	08				
11061-7010	08	16126-7020	01	56071-0366	12	92145-1653	03				
11061-7086	09	16146-7013	11	56080-0746	12	92145-1809	04				
11061-7087	08	16154-7010	04	59031-7017	06	92145-1811	07				
11061-7088	08	16154-7011	04	59041-7014	05	92145-1812	07				
11061-7093	08	16171-0042	07	59066-0043	05	92150-2182	07				
11061-7094	01	16186-7006	08	59071-0733	01	92152-1689	03				
12004-0733	03	172BA0822	01	59076-0009	08	92153-0009	07				
12005-0777	03	21039-7002	11	59231-0746	04	92153-7007	05				
12009-7001	03	21066-7017	06	670B2011	01	92153-7008	04				
12011-2056	03	21080-0009	11	92004-0723	08	92153-7034	11				
12016-0040	03	21163-0749	11	92009-2083	08	92153-7054	01				
12032-7001	03	21171-0758	06	92009-2303	06	92153-7100	03				
13001-7027	02	21188-7002	08	92009-2303	10	92154-1267	03				
13002-0704	02	21193-0036	06	92009-2308	06	92154-2687	05				
13008-0569	02	23062-7024	05	92009-2349	08	92154-2697	07				
13025-7009	02	26011-2234	06	92009-2402	08	92154-2842	02				
13029-7010	02	26031-7040	06	92015-1367	09	92154-2938	01				
13031-0824	02	26031-7041	06	92026-7007	05	92154-2938	04				
13070-7017	03	27010-0818	06	92033-0778	03	92154-2938	05				
130BA0620	06	27012-7008	11	92033-0790	02	92154-2938	07				
130BA0625	01	311BA0600	07	92038-2101	02	92154-7003	06				
130BA0630	08	312AA0500	07	92039-0751	05	92170-2009	10				
130BA0840	11	312AA0600	03	92043-0858	01	92170-2042	09				
130CA1050	01	32155-2214	01	92043-1263	01	92170-7001	07				
130CA1065	01	39074-7001	08	92049-7001	01	92172-0792	07				
13101-0650	11	39129-7035	07	92049-7010	01	92172-0870	01				
13107-7018	08	39184-0019	11	92049-7019	01	92172-0870	07				
13107-7047	07	411AA0600	07	92049-7028	01	92172-7018	06				
13116-0725	03	42036-7015	10	92055-0892	04	92173-1000	10				
13251-0719	02	42036-7021	03	92055-7025	09	92173-1001	09				
13271-7007	03	42036-7022	09	92063-7141	08	92173-7003	09				
13271-7021	03	49015-0023	01	92063-7142	08	92173-7010	09				
13271-7038	07	49019-0027	10	92063-7149	08	92192-1551	10				
13272-1374	01	49040-0770	10	92066-0095	09	92192-1555	10				
13272-1487	05	49065-7006	04	92066-0774	04	92192-7146	09				
13272-7011	04	49065-7007	04	92066-0880	01	92192-7148	10				
13272-7012	06	49078-7002	03	92066-0881	01	92192-7165	09				
14037-7008-9H	05	49089-0991	05	92066-2204	08	92200-0848	08				



**Kawasaki Heavy Industries, Ltd.**

Motorcycle & Engine Company

Part No. 99908-6164-02